

FULL COVERAGE GROUND SUPPORT – RECENT TRENDS IN AUSTRALIAN MINING PRACTICE

P G Fuller

BFP Consultants Pty Ltd, Melbourne, Australia

P M Dight

BFP Consultants Pty Ltd, Perth, Australia

G Davison

Mining One Pty Ltd, Melbourne, Australia

ABSTRACT: The issue of what constitutes supported ground in Australian underground mining has changed considerably in the last five years. Prior to that it usually meant that the ground had been rock bolted so the risk of a ground fall from either between bolts or around them was minimal. Now, due in part to legislation and the self imposed requirement by mining companies to improve safety in underground operations, additional support to achieve total coverage of backs and upper sidewalls of excavation.

This paper examines the impact of full coverage support methods on support costs and support installation time per metre advance of a typical opening. It also compares the cost of mesh, shotcrete and spray-on membrane types of full coverage support. A recent example of a change from mesh to shotcrete has highlighted the economic, operational and safety benefits that the shotcrete method can offer. Further refinement of the development cycle is suggested as a way of reducing cycle time where spray-on type full coverage support is to be used.

1. INTRODUCTION

Prior to the release of regulations related to the Mines Safety and Inspection Act 1994 in Western Australia (WA), ground support in underground metal mines in Australia usually involved the installation of rock bolts in the backs of standard 4.5m to 5m wide openings. This was supplemented by cable bolts, where back spans were greater or specific deeper seated ground falls were considered to be a potential problem. Some mine owners preferred bolts to be placed with a specific pattern whereas others just required a certain density of bolting without defining any pattern. In many operations, neither bolt density nor placement pattern was specified and supervisors relied on their experience to feel comfortable that the amount of installed ground support was adequate to maintain stable ground conditions. This usually meant that they informally assessed the risk of a ground fall from between the bolt array to be low.

Where ground conditions were friable or there was sufficient structure or fracturing of the surface due to blast damage to cause the rock mass to unravel from between rock bolts, operators used either 280mm wide steel straps or weldmesh (screen) with nominal 100mm square aperture size and wire diameters of 5 or 6mm to provide interbolt restraint of the surface. An alternative approach was to

reduce the bolt spacing and increase the area of influence of each bolt with a 300mm x 280mm “butterfly” plate placed behind rock bolt plates. The choice between this approach and full coverage support with mesh was largely related to operator experience and to the total installed cost.

A spate of injuries and fatalities from rock falls resulted in the WA Mines Inspectorate revisiting the Mines Safety and Inspection Act relating to safe work practices. The intent of this was to reduce the risk of work-related injury and disease. Part of this involved the specification of a code of practice for surface rock support; meaning full coverage support. It assumed that sufficient rock bolting would be installed to ensure the general structural stability of the excavation in which people may travel or work. Primarily, the code required that full coverage support would be mandatory in mine openings greater than 3.5m high in all WA underground mines unless a documented geotechnical risk assessment justified otherwise [1]. This requirement applied to both the back and sidewalls higher than 3.5m above the floor. It related only to potential gravity induced rock falls and any predicted dynamic failure mechanisms were to be assessed separately according to the identified risk.

Compliance with this code of practice is only a legislative requirement in WA but in practice it has been recognised by the mining industry nationally that a close variant of the code is highly likely to become an operating requirement in all other Australian states.

In broad terms, this paper describes the response of the underground metal mining industry to this change in ground support regulations and in particular examines the impact of it on mine development efficiency and cost.

2. OPERATOR RESPONSE TO NEW GROUND SUPPORT CODE

When faced with the choice dictated by the new ground support code of either installing full coverage support or justifying that it was not required, most WA mine owners opted for blanket coverage with mesh support. In part, this decision was forced upon smaller operations because these did not have the geotechnical expertise on site to conduct risk assessments and they considered it impractical to engage geotechnical consultants to undertake this work. This was particularly the case at mines where ground conditions were highly variable and risk assessments would have been virtually a full time activity. Also, experience with the conduct of geotechnical risk assessments was limited and mine management preferred the practical solution rather than the outcome of an incomplete or poorly founded geotechnical risk assessment that could be difficult to defend in the event of an injury causing ground fall.

More recently some operations have changed to shotcrete for full coverage support of backs and upper walls. Spray-on membranes have undergone field trials and are currently being evaluated at a number of mines.

2.1. Mesh

Mesh installation was the easiest form of full coverage support to install with twin boom Jumbos that were common throughout WA. However, since miners were not to be exposed to unsupported ground, backs needed to be bolted before mesh could be loaded onto the Jumbo boom prior to its installation. Thus, mesh installation has resulted in over-bolting where the regulatory requirements have been followed. Where mesh has been installed with the initial bolting, Thompson et al [2] noted that with standard 2.4m wide mesh sheets, bolt spacing had decreased from typically 1.2m down to 1.1m. This had been necessary to achieve the tightest possible contact between the mesh and the

undulating rock surface to minimise the unsupported area not in contact with either the mesh or rock bolt plates.

The duty of the mesh has rarely, if ever been considered at the operational level. There have been various studies on both the load capacity and the support stiffness offered by pinned mesh but this has been of academic interest only to operators. From experience they know that:

- keeping the mesh as tight as possible to the exposed rock surface minimises the possibility of it becoming overloaded due to overbreak,
- if mesh deforms excessively between rock bolts due to rock overbreak, there is an increased risk that it may fail with potentially hazardous consequences, and
- additional bolting can reduce unpinned spans in the mesh which can delay the time consuming and costly practice of bleeding broken rock from mesh.

2.2. Shotcrete

Few mines in Australia batch and apply their own shotcrete. Traditionally, most mines have not acquired the appropriate capital equipment and therefore have relied on contractors for shotcrete batching and application. Two exceptions known to the authors are the Pasminco Mine at Broken Hill, NSW and the now closed Woodlawn Mine near Tarago, NSW. At Woodlawn, initial trials with dry mix shotcrete using a small Allentown shotcreter demonstrated that shotcrete could stabilise the exposed surface of the highly sheared and talcose rock mass. A transition from dry to wet mix shotcrete at Woodlawn resulted in significant improvements in ease of application. It became obvious that a wet shotcrete system was a solution for the difficult Woodlawn ground, but the high capital and operating cost of applying shotcrete needed to be addressed. Woodlawn then embarked on a project to build a shotcrete machine capable of:

- high speed shotcrete application,
- spraying backs up to 9m high,
- a relatively fast tramming speed ,
- remote application of shotcrete, and
- having machinery parts common with the existing equipment fleet.

The shotcrete machine utilised a redundant jumbo carrier onto which a 35m³/hour capacity, double action, concrete pump was installed. The boom was modified by centring the roll-over actuation mechanism and increasing its extension to enable it to apply shotcrete at a maximum reach of 9 metres (Plate 1).



Plate 1. Modified Jumbo based Shotcrete Machine

A simplified batch plant was purchased along with a secondhand, 5m³ capacity standard concrete agitator truck to provide the necessary material feed to the machine (Plate 2).



Plate 2. Batch Plant and Agitator

Shotcrete materials supply was addressed at Woodlawn by developing a standard 5m³ batch of product and arranging for the required 1.8 tonnes of cement to be supplied in two, 0.9 tonne “bulkabags”. This overcame the need for a cement silo and also would allow the cement to be delivered to an underground shotcrete mixing facility, if that was desirable.

In a short time, operators become skilled in the sequencing of placement achieved a consistent minimum thickness. Various ideas were tried to control thickness but the most practical solution was to apply a known volume of shotcrete to a marked up area of rock surface, after allowing for wastage. More recently, McGowan [3] has described the use of a probe on the shotcrete boom for testing the thickness of the “as sprayed” layer. This allowed any thin areas detected by the probe to be re-sprayed before the shotcrete cured and created a weak interface within the layer.

Experience of shotcrete implementation at both Woodlawn [4,5] and the Black Swan Mine [3] were that many miners were initially sceptical about the method compared to the bolted mesh alternative. This was particularly the case where sprayed shotcrete was applied to a local area of bad ground rather than forming a complete lining in the opening

which is common in tunnelling. However, the improved stability that was achieved, particularly with very poor quality rock quickly changed these perceptions to one of widespread acceptance. In the case of Black Swan, this acceptance was so strong that management had to counter the notion among miners that shotcrete was the remedy for all of their ground support problems.

There has been some debate about whether rock bolts should be installed before or after applying shotcrete. At Woodlawn it was demonstrated that the initial application of shotcrete followed by bolting was far superior. The shotcrete effectively changed the rock mass quality of the friable surface and the subsequent bolting through the shotcrete layer allowed rock bolt plates acting on the shotcrete to apply more uniform restraint to the rock surface.

The main limitations to the more widespread use of shotcrete for total coverage support in the mining industry have been the cost and the logistics of materials handling. Woodlawn’s approach was to drive costs down by developing a mine owned and operated facility that allowed bulk handling of materials. This owner operator approach has not been widespread and the majority of operating mines where shotcrete is used rely on contractors for that component of ground support.

2.3. *Spray-on Membranes*

Membranes have been seen as an alternative to shotcrete as there is less material to handle and the latex based products appear to be relatively inexpensive compared to some contractor applied shotcrete. However, to date this alternative form of full coverage support is not in widespread use in Australia. The materials handling problems encountered in other parts of the world as described by Finn [6], are not as much of a problem in Australia's relatively shallow, predominantly decline accessed mines. The hazardous nature of components that make up the “chemical based” membranes and the poor performance of some membranes compared to mesh and shotcrete has also restricted their widespread use.

3. COST OF FULL COVERAGE SUPPORT

3.1. *Mesh*

The cost of installed mesh depends on many factors that can vary from mine to mine depending on the way the mesh component costs are allocated. One example of a WA mine where mesh is used and support consumable costs are known and separately identified, has support costs as itemised in Table 1.

Costs are based on the bolts and mesh required to

Table 1 - Support Costs for a 5m x 5m Drive with and without Mesh

Component	Specification	Unit Cost (A\$)	Support with Mesh		Support without Mesh	
			No./Time	Cost (A\$)	No./Time	Cost (A\$)
Metres advance			5.4		6	
Mesh	6 sheets 2.4m x 3.0m. 300mm overlap	32.00	6	192.00	-	-
Bolt - back	2.4m long, 46mm dia. friction bolt, galv.	10.70	35	374.50	20	214.00
- wall	As above	10.70	20	214.00	20	214.00
- insert	0.9m, 39mm dia., galv.	4.00	14	56.00	-	-
Plate	butterfly plate and washer	4.00	69	276.00	40	160.00
Equipment and Labour	Twin boom jumbo & operator	310.00 per hour	9.2 hours	2852.00	5.0 hours	1550.00
Total Cost (A\$)				3964.50		2138.00
Cost (A\$/m advance)				734.17		356.33
Installation Time/m advance (hours/m)				1.70		0.83

support a 5.4m long section of a drive to the standard required by the WA code of practice. Support costs for bolting (without mesh) of a 6m length of drive in the same ground conditions are presented for comparison purposes. The component

numbers in the table have been derived from the bolting/meshing pattern in Fig. 1 and from bolting patterns used when surface support was not required (Fig. 2).

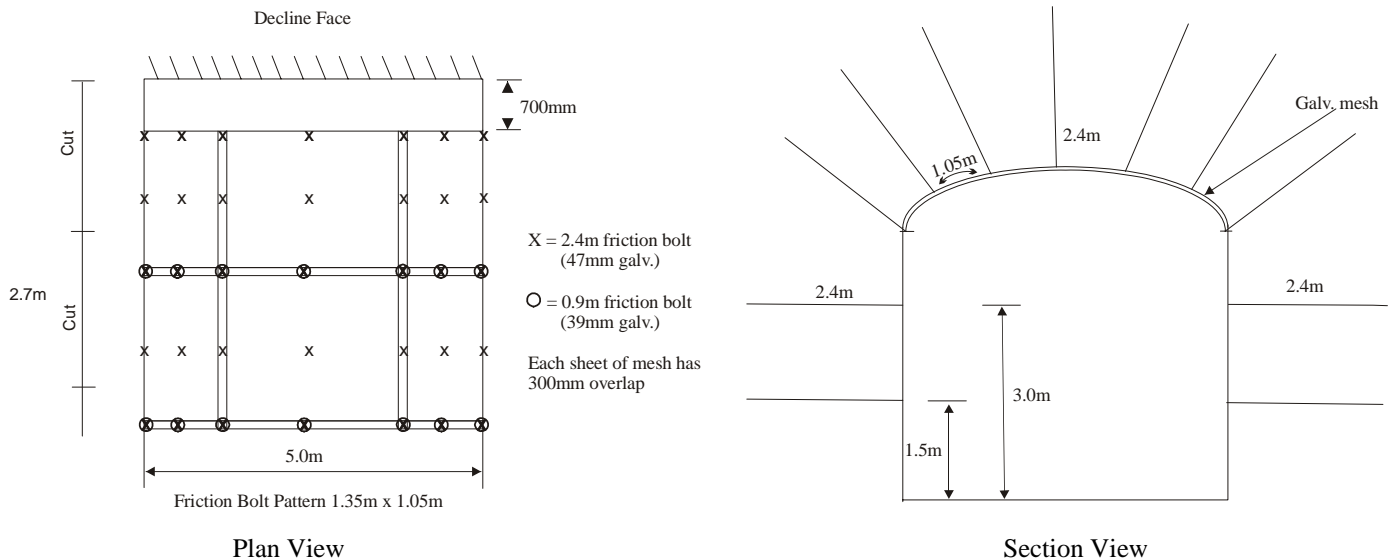

Fig. 1 Typical Bolting Pattern with Mesh

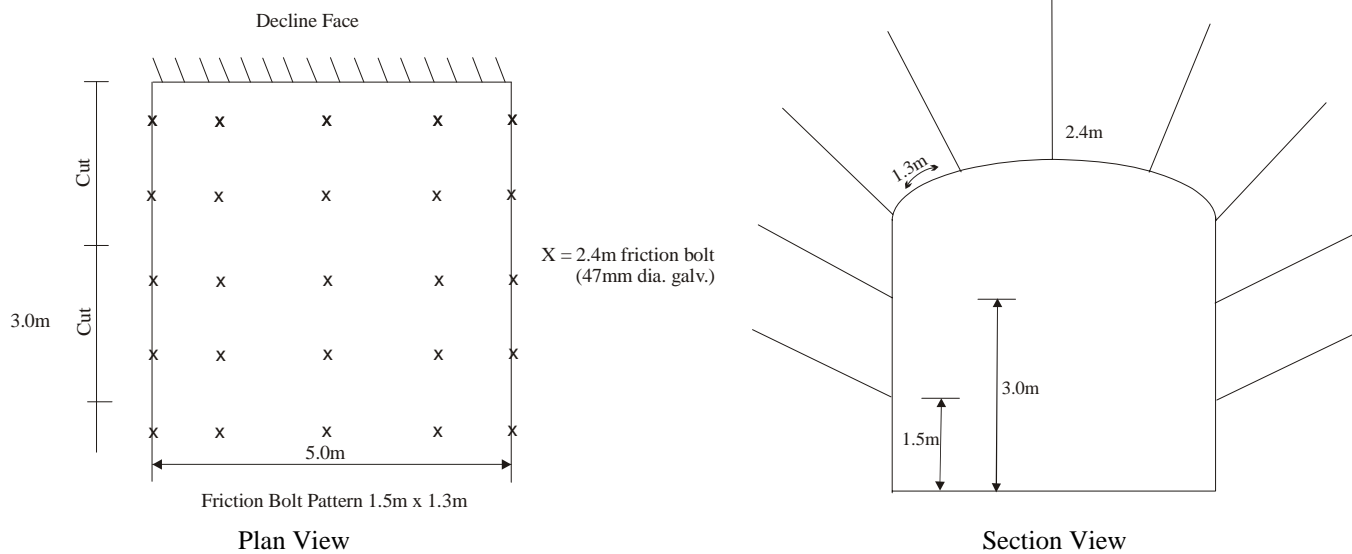

Fig. 2 Typical Bolting Pattern without Mesh

Lateral bolt spacings are approximate and depend on the curvature of the back.

The overall cost of A\$310/hr for a Jumbo and operator is based on a Jumbo cost of A\$250/hr which includes depreciation, maintenance, fuel and lubricants and A\$60/hr for the cost of the operator.

Table 1 shows the total cost for mesh installation to be A\$734/m of advance compared to a bolt only support option of A\$356/m advance. In addition to this 106% cost increase to install mesh, Table 1 shows that the support installation time per metre of advance increases by 105% when mesh is included.

3.2. Shotcrete

Shotcrete costs in Australia are variable depending on the amount and type of fibre-reinforcement used and on whether it is supplied as part of the mining operation or by a contractor. At Woodlawn, the development and construction of the shotcreting facility was completed for a cost of approximately A\$220,000. Consumable storage was sufficient to allow the mine to directly purchase shotcrete consumables in bulk, thereby keeping the price of concrete and shotcrete to a minimum. In 1998, shotcrete materials costs at Woodlawn were A\$170/m³ of mix which increased to A\$257/m³ when steel fibres were added. Labour and equipment costs, allowing for depreciation, fuel, oils and maintenance for the placement of steel fibre reinforced shotcrete was A\$110/m³ resulting in a total cost of A\$367/m³. While some cost items would need to be increased to reflect current costs, the cost of steel fibres has reduced and the fibre dose of 50kgs/m³ of mix could probably be reduced without any adverse effect on as-placed shotcrete properties.

Contractor rates for shotcrete vary from A\$600/m³ to A\$1200/m³ depending on location, size of contract and shotcrete specification.

In a 5m x 5m drive, applying a 50mm thick layer of shotcrete on the back and upper wall of each side of the drive with 10% rebound requires material feed at a rate of 0.385m³/m advance.

On this basis, the cost for contractor applied shotcrete varies from A\$231 to A\$462/m advance compared to the Woodlawn cost of A\$155/m advance after allowing a 10% increase to account for cost increases since 1998. These rates convert to the following cost per m² of coverage;

	A\$/m ²
Woodlawn Mine	22
Contractor minimum	33
Contractor maximum	66

3.3. Spray-on Membranes

The cost of applying latex based membranes has been quoted to be A\$35/m² and is almost identical to the minimum rate for contractor applied 50mm thick shotcrete.

3.4. Comparison between Mesh and Shotcrete

For the example of mesh support in a 5m x 5m drive shown in Fig. 1 with costs outlined in Table 1, the additional cost of applying mesh is A\$378/m advance. This is 2.4 times the Woodlawn mine shotcrete cost and lies within the upper part of the cost range for contractor applied shotcrete of A\$231 – 462/m.

There has been a perception among some mine owners that the cost of contractor applied shotcrete is prohibitively high compared to the cost of mesh placement. This comparison clearly shows that this

is not the case. The reason for the approximate cost parity between mesh and shotcrete placement is the extra cost of bolting required to properly pin the mesh to the exposed rock surface.

A recent example in the Gympie Mine decline where shotcrete has replaced mesh, has reduced the rock bolt usage from 8.3 to 3.6 bolts/m advance in a 5m wide x 5.5m high heading [7]. 45mm thick nylon-fibre filled shotcrete was applied after bolting and because of the overlap requirement with mesh sheets, 8.8m² of mesh was replaced with an areal coverage 7.67m² of shotcrete.

A five week trial of the shotcrete-bolt alternative to mesh and bolts achieved a reported 16% saving in total ground support unit costs and an overall cost saving greater than 10% [7]. With further refinement of installation procedures and more experience, the mine owner at Gympie expects cost reductions of at least 20% to be achievable.

Development advance rates with shotcrete and bolting were 10-15% greater than the average rate achieved with the former bolted mesh system. This was largely due to the lower rock bolt usage with the shotcrete based method. Mine owners at Gympie have cited flow-on benefits from their change from mesh to shotcrete as:

- reduced operator injury potential with not having to handle heavy sheets of mesh,
- reduced risk of damaging ventilation bags because of less sharp edges with the shotcrete lining, and
- easier and safer repairing of any damaged area of shotcrete.

4. FUTURE TRENDS WITH FULL COVERAGE SUPPORT

There is no doubt that full coverage support will become even more widely used in Australian mining as the WA ground support code becomes the minimum standard that is acceptable nationally. In the 21st century, the requirement for mine owners to protect employees from danger in the workplace is indisputable. The issue is how to achieve this while still retaining a profitable mining process. More mine owners are now realising the benefits that thorough geotechnical risk assessments can offer but also appreciate that there are often substantial risks of rock falls when only rock bolts are used for back support.

In the short term, more Australian mine owners will recognise the advantages of using some form of spray-on support compared to mesh. Already they are re-examining development cycles as outlined by

McGowan [3] in which the typical mesh installation cycle was described as:

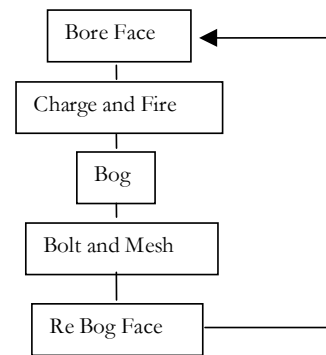

The change at the Black Swan mine [3] to the cycle with fibre-reinforced shotcrete comprising:

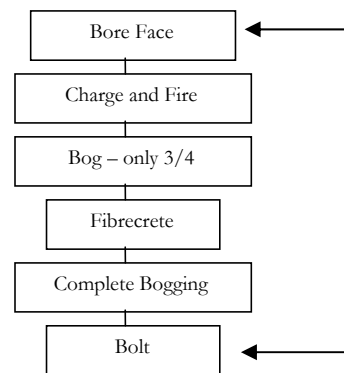

has reduced cycle times and reduced the risk of operator exposure to unsupported ground.

Further improvements may be possible with spray-on full coverage support by scaling with a high pressure water-jet on the boom of the shotcrete machine or membrane spray before bogging. This may require cleaning any debris from the floor with a small blade on the front of the shotcrete machine but it would allow machine usage to be streamlined. Mucking would commence under supported ground and the mucking cycle would be less likely to be interrupted due to ground falls.

Water jet scaling may initiate surface failure in burst prone ground but this may prove beneficial in creating more stable conditions prior to shotcrete application.

With shotcrete type full coverage support, the recent trend has been for mine owners to only consider the option of contracting that part of the overall support to a separate contractor. While this may be the most cost effective approach where shotcrete is only needed for irregular one-off applications, the Woodlawn mine experience indicates that a mine owned and operated shotcrete facility can lead to significant cost savings where shotcrete is more universally applied. From the shotcrete costs in section 3.2, a mine undertaking 3 km of

development per year could save A\$0.5M per year by implementing an owner operated shotcrete system.

5. CONCLUDING REMARKS

The need for WA mine owners to adhere to the code of practice for ground support has significantly increased mesh usage for full coverage support. As a result, support costs for a typical 5m x 5m drive have more than doubled mainly due to the amount of additional rock bolting required to pin mesh sheets to the rock surface. The time to install support with mesh is more than twice that required for rock bolt support.

Shotcrete is becoming a viable alternative to mesh even where contract prices are relatively high because it offers potential improvements in advance rates and can be placed with less risk to mine operators. In mines, where shotcrete usage is high, there is economic incentive to move to an owner operated shotcrete facility.

Spray-on membranes have been trialled in a number Australian mines but have yet to gain widespread acceptance as a replacement for either mesh or shotcrete.

REFERENCES

1. Surface Rock Support for Underground Mines – Code of Practice. 1999. Mines Occ. Safety and Health Advisory Board (MOSHAB), Western Australia.
2. Thompson, A.G., C.R. Windsor, and G.W. Cadby. 1999. Performance assessment of mesh for ground control applications. In *Proceedings of the International Symposium on Rock Support and Reinforcement Practice in Mining, Kalgoorlie, 15-17 March 1999*, eds E. Villaescusa et al, 119 – 130. Rotterdam: Balkema.
3. McGowan, D. 2001. Becoming thick skinned - Black Swan's experience with shotcrete. In *An International Seminar and Field Trials on Mine Surface Support Liners, Perth, 23-24 August 2001*, Australian Centre for Geomechanics, 12, 1-9.
4. Davison, G. 1995. Woodlawn mine - an underground operation review. In *Proceedings of the Underground Operators' Conference, Kalgoorlie, 13-14 November 1995*, The Australasian Institute of Mining and Metallurgy, Kalgoorlie Branch and The Western Australian School of Mines, 259-263.
5. Davison, G., and P.G. Fuller. 1998. Woodlawn mine - Ground control challenges and solutions. In *Proceedings of the Seventh AusIMM Underground Operators' Conference, 30 June-3 July 1998, Townsville*. The Australasian Institute of Mining and Metallurgy, Publication Series No. 3/98, 121-125.
6. Finn, D. 2001. Polymer membrane tests. Black Swan's experience with shotcrete. In *An International Seminar*

and Field Trials on Mine Surface Support Liners, Perth, 23-24 August 2001. Australian Centre for Geomechanics, 20, 1-20.

7. Lewis adopts new mix. 2002. *Australia's Mining Monthly, February 2002*, 60.